



**PERFORMANCE DATA SHEET  
NEMA PREMIUM NR CAN NEMA 12 - 12**

Catalogue #: MQP-32

HP	kW	Voltage	S.F. @ 60Hz	EFF.	P.F.	Frame	Design	L.R. Amps
10	7,46	230/460	1,25	91,7%	0,81	215T	B	81

60 Hz								Code	F.L. RPM
208	230	416	460	480	575	600			
/	25	/	12,50	/	/			H	1770

50 Hz								
FLA			S.F. @ 50Hz	Efficiency	Power Factor	Code	F.L. RPM	
190	380	415						
30,0	15		1,00	89,5%	0,840	E	1460	

Wgt. Lbs	PH	Duty	Insul. Class	Amb.	Elevation	Temp. Rise° C
167	3	Cont.	F	40°C	1000M (3,300 Ft)	53

% Efficiency		% Power Factor		Torque		Winding Resist. Ω	Safe Cold Start (Secs)
Full Load:	91,7%	Full Load:	0,81	Full Load Ft/Lbs	29,7		
3/4 Load:	91,8%	3/4 Load:	0,77	Locked Rotor %	170		
1/2 Load:	90,0%	1/2 Load:	0,67	Break Down %	280	1,06	20

Rotor Inertia Wk2 Lb-Ft2	Max Load Inertia Wk2 Lb-Ft2	Shaft Material	Frame Material	DE Bracket Type	ODE Bracket Type	Enclosure	NEMA Rating	Lead Wire Size
0,71	75	1045	Cast Iron	Cast Iron	Cast Iron	TEFC	IP55	14 AWG

Ball Bearings		Grease	Mount Type	Orientation	Paint	Sound Pressure @ 3FT	Sound Power
DE	ODE						
6308	6308	Sealed Bearings	Rigid	Horizontal	RAL6022	69	79

Inverter Duty, Motor meets MG1 parts 31.4.4.2	VFD SF	Constant Torque Range	Variable Torque Range	Constant HP RPM
	1,00	10:1	20:1	2700

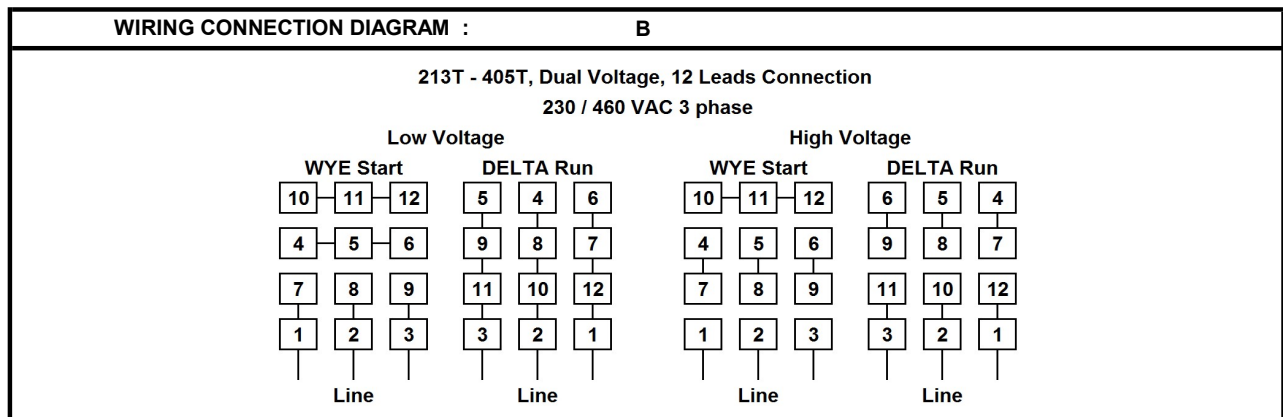

Date: 2023-12-13  
 Customer: \_\_\_\_\_  
 Contact: \_\_\_\_\_  
 Submittee: J.C. Lavallée

Catalogue #: MQP-32

NEMA PREMIUM NR CAN NEMA 12 - 12										
HP	VAC	RPM	Enclosure	Frame	Frequency	Design	Poles	LR Code Letter	Insulation Class	Temp. Rise °C
10	460	1770	TEFC	215T	60 Hz	B	4	H	F	53
	0Hz	6Hz	15Hz	30Hz	45Hz	60 Hz	75Hz	90Hz	105Hz	120Hz
Amps	9,1	9,1	9,1	9,1	9,1	9,1	9,1	9,1	9,1	9,1
RPM	0	352,5	881,25	1762,5	2643,75	3525	4406,25	5287,5	6168,75	7050
Torq ft.lb	11,92	11,92	14,90	14,90	14,90	14,90	11,92	9,93	8,51	7,45
Peak Tq ft.lb	18,25	36,50	36,50	36,50	36,50	36,50	29,20	24,34	20,86	18,25
HP	0	0,8	2,5	5,0	7,5	10,0	10,0	10,0	10,0	10,0
	Locked Rotor	Pull-Up	Breakdown	Rated Load	Idle	Duty	S. F.	Ambient	Elevation	dBA @ 1M
Speed (RPM)	0,0	756	1440	1770	1800	Continuous	1,25	40°C	3,300 ft	69
Current (Amps)	81,0	68,9	48,2	9,1	3,5	VFD Rating: Meets MG1 parts 31.4.4.2				
Torque (ft.-lbs)	26,8	20,1	43,2	14,9	0,0	C.T.	10:1	V.T.	20:1	VFD SF 1.00

Motor Speed Data

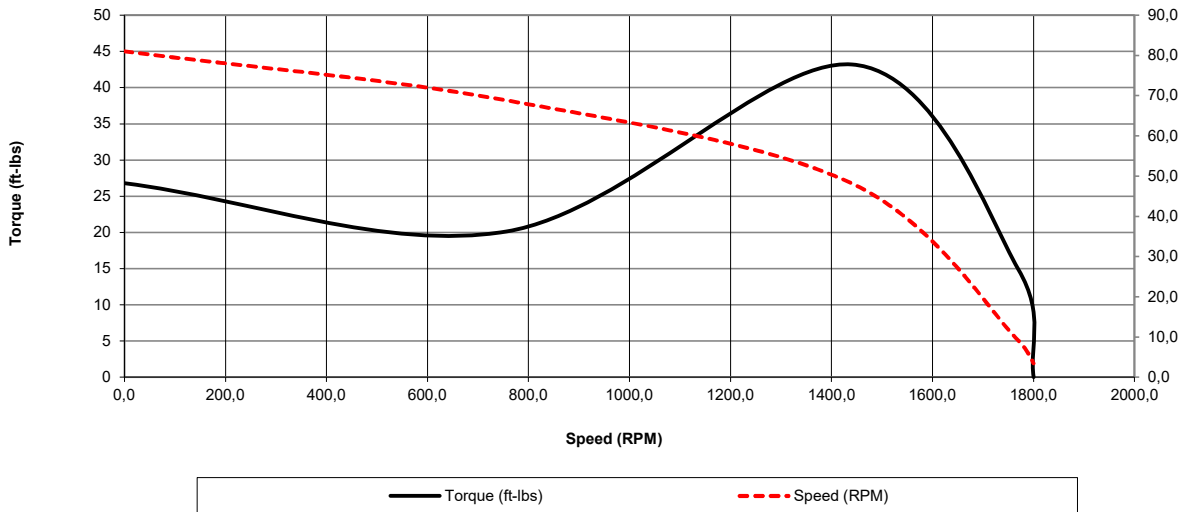

Motor Torque Capability vs RPM

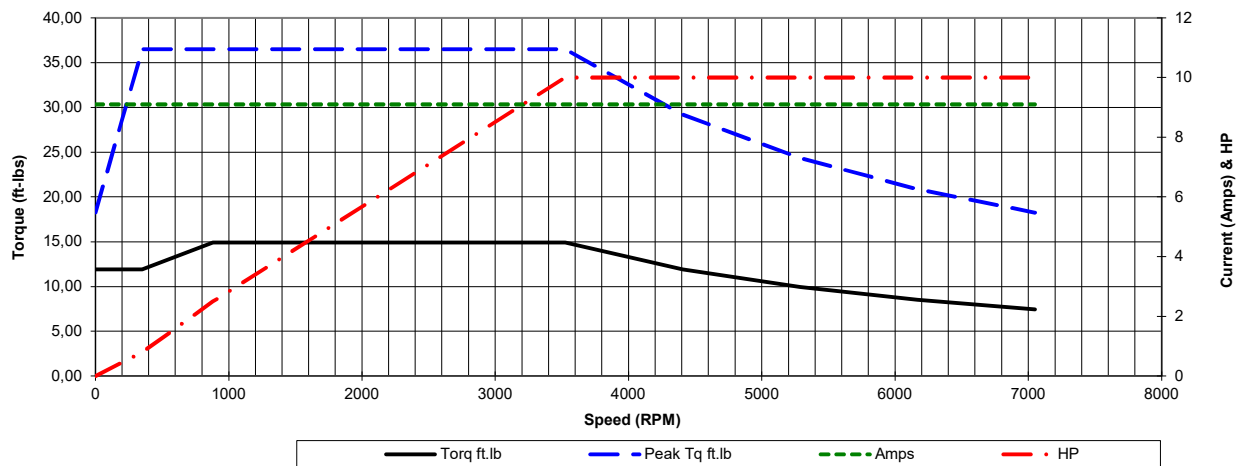



Date: 2023-12-13  
 Customer: \_\_\_\_\_  
 Contact: \_\_\_\_\_  
 Submittee: J.C. Lavallée

Catalogue #: **MQP-32**

NEMA PREMIUM NR CAN NEMA 12 - 12										
HP	VAC	RPM	Enclosure	Frame	Frequency	Design	Poles	LR Code Letter	Insulation Class	Temp. Rise °C
10	460	1770	TEFC	215T	60 Hz	B	4	H	F	53
<b>Load %</b>	<b>0%</b>	<b>25%</b>	<b>50%</b>	<b>75%</b>	<b>100%</b>	<b>125%</b>	<b>150%</b>			
<b>Amps</b>	3,46	3,89	5,39	7,11	9,10	11,32	13,55			
<b>Torq ft/lbs</b>	0	3,67	7,37	11,12	14,90	18,72	22,59			
<b>RPM</b>	0	3581,25	3562,5	3543,75	3525	3506,25	3487,5			
<b>Eff</b>	0	96,39	87,00	89,40	90,20	88,78	88,43			
<b>PF</b>	0	50	82	88,2	92	93,196	93,748			
	<b>Locked Rotor</b>	<b>Pull-Up</b>	<b>Breakdown</b>	<b>Rated Load</b>	<b>Idle</b>	<b>Duty</b>	<b>S. F.</b>	<b>Ambient</b>	<b>Elevation</b>	<b>dBa @ 1M</b>
<b>Speed (RPM)</b>	0	756	1440	1770	1800	Continuous	1,25	40°C	3,300 ft	69
<b>Current (Amps)</b>	81	68,9	48,2	9,1	3,458	<b>VFD Rating: Meets MG1 parts 31.4.4.2</b>				
<b>Torque (ft-lbs)</b>	26,82	20,11	43,21	14,90	0,0	C.T.	10:1	V.T.	20:1	VFD SF 1.00

